

由于我们在不断努力改进产品，我们保留样本数据更改的权利，敬请谅解！

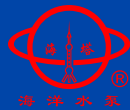
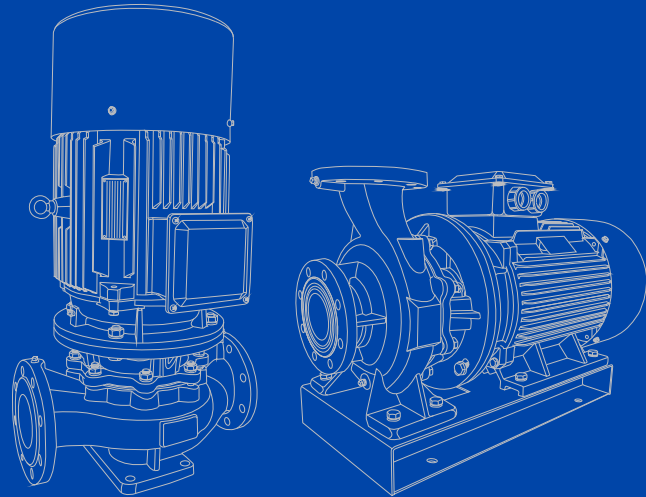

Shanghai Sea
Pump & Valve Mfg Co., Ltd

上海海洋泵阀制造有限公司

地址：上海市金山区山富东路365号
电话：(0086)-021-63546554 63803848
传真：(0086)-021-33550508
网址：www.sea-pump.com
邮箱：seapump@foxmail.com

Address: 365 Shanfu East Road, Jinshan District, Shanghai
TEL: (0086)-021-63546554 63803848
FAX: (0086)-021-33550508
WEB: www.sea-pump.com
E-mail: seapump@foxmail.com



ISG、ISW
管道离心泵
PIPELINE CENTRIFUGAL PUMP

使用说明书
Operating instructions

SEAPUMP

上海海洋泵阀制造有限公司
SHANGHAI SEA PUMP & VALVE MFG CO., LTD



企业简介 + AOBUTS

上海海洋泵阀制造有限公司是专业从事水泵、生活消防设备及水泵智能控制开发、生产、销售为一体的股份制企业，本公司运用先进的软件开发、设计产品保证了向顾客提供更优质的产品。

“海洋水泵，泵的海洋”，海洋产品在全国各地设有分公司以及售后服务处，产品已应用于工矿企业、城市污水处理、城市供水、石油化工、农业灌溉等行业。本厂资金雄厚，生产设备先进，检测手段完善，并拥有一批高素质的专业人才队伍，同时ISO9001:2000国际质量管理体系的良好动作，为制造出优质、可靠的产品打下坚实基础。

本公司在“以人为本，科技兴业；以诚为用，质量立业；勇于开拓，锐意进取；追求卓越，走向未来”的方针指导下，不断开拓进取创新发展，在长期的实践中形成了一套完整的质量体系，并配备了一支安装调试维护的售后服务队伍。销售网点辐射全国各大城市，产品行销全国各省、市、自治区，并出口东南亚等国。并以一流的产品、一流的服务赢得了国内外广大用户的信赖和好评。本公司以“一切为了顾客的满意”为宗旨，继往开来，与时俱进。服务于人类建设美好家园。

Shanghai HAIYANG pump & valve Co., Ltd. Is a joint-stock enterprises which specializes in the manufacture of water pumps, fire fighting equipment and pumps intelligent controlling production, sales in one. our company uses advanced software to develop and design products to ensure that customers provide better quality products.

"HAIYANG water pumps, pump of the sea", the HAIYANG products throughout the country with more than 30 branch offices as well as after-sales service, products have been used in industrial and mining enterprises, urban sewage treatment, urban water supply, petrochemicals, agriculture and irrigation sectors. Factory with a strong financial background, advanced production equipment and means of improving the detection and has a number of high-quality professional talent, while ISO9001:2000 international quality management system of good moves, in order to create high-quality, reliable products to lay a solid foundation.

In this "people-oriented, Industrial Science and Technology; to use for Prudential, the quality of establishing themselves; to open up the courage to strive for progress; the pursuit of excellence, into the future" under the guidance of continuous innovation and development to forge ahead in long-term practice of the formation of a complete set of The quality system and is equipped with an installation of the maintenance of after-sales service team. Radiation sales outlets in major cities nationwide, product marketing provinces, municipalities and autonomous regions, and exports in countries such as South-East Asia. And first-class products, first-class service to win customers at home and abroad trust and praise. The Company take "everything for the customer satisfied" as the purpose, advance with the times, in the service of humanity home.



Contents

型号意义	01	Type designation
产品概述	01	Product Introduction
产品特点	02	Product Features
主要用途	02	Chief Usage
工作条件	03	Working Conditions
结构说明	03	Structure Description
结构图	04	Structure diagram
结构材料表	04	List of structural materials
性能参数	05-12	Performance parameter
安装	13	Installation
安装方式	13	Installation Mode
启动与停车	14	Start and stop of the pump
泵的维护	14	Maintenance of pump
故障原因和解决方法	15	Causes of failure and solutions
管路损耗参考表	16	Pipeline friction loss table



型号意义 Type designation

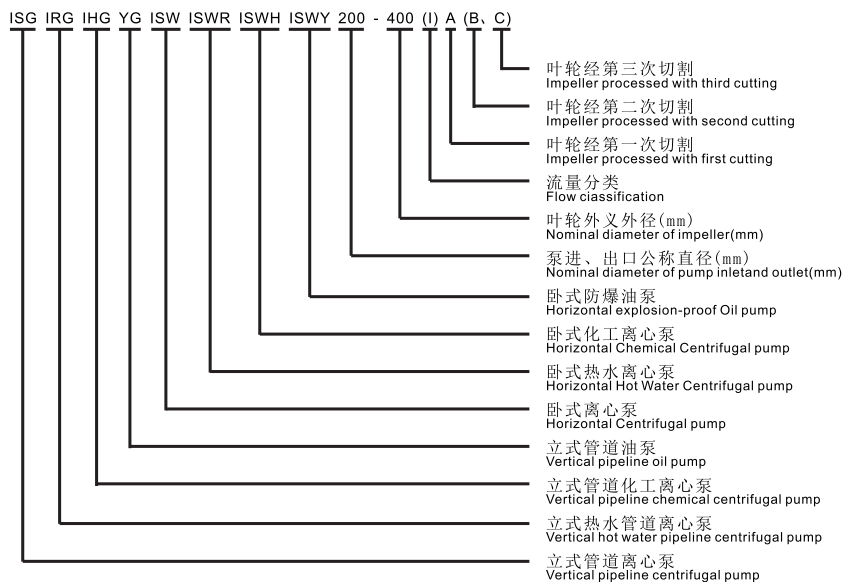

产品概述

ISG, ISW系列单级单吸管道离心泵是本公司参照国际标准ISO2858和国家标准JB/T6878.2-93所规定的性能参数,结合本公司多年生产经验而设计的第二代高效节能产品,是替代SG型管道离心泵、IS型离心泵、D型多级离心泵等常规泵的理想产品。系列流量范围1.5~1600m³/h,扬程范围5~150m,分基本型、分流型、切割型等多种规格。根据使用场合介质和温度的不同,过流部份的材质变化及结构变化,设计制造成同性能参数的热水泵、管道化工泵、管道油泵,使该系列产品的使用得到普及。完全可以替代常规离心泵在所有场合使用。

Product Introduction

ISG and ISW series single-stage single suction pipeline centrifugal pumps are the second generation of high-efficiency and energy-saving products designed by our company with reference to the performance parameters specified in the international standard ISO2858 and the national standard JB / t6878.2-93 and combined with our many years of production experience. They are ideal products to replace SG pipeline centrifugal pumps, IS centrifugal pumps, D-type multistage centrifugal pumps and other conventional pumps. The series has a flow range of 1.5 ~ 1600 cubic meters per hour and a lift range of 5 ~ 150 meters. It is divided into basic type, shunt type, cutting type and other specifications. According to the different medium and temperature of the application occasion, the material change and structural change of the overflow part, the hot water pump, pipeline chemical pump and pipeline oil pump with the same energy parameters are designed and manufactured to popularize the use of this series of products. It can completely replace the conventional centrifugal pump and be used in all occasions.



产品特点

- 1、泵结构紧凑、体积小、外形美观,其立式结构决定安装占地面积小。
- 2、安装方便,进、出口径相同并在同一中心线上,无需改变管路。
- 3、泵运行平稳、噪音低、组件同心度高。
- 4、密封可靠、无泄漏。轴封采用硬质合金及碳化硅等耐磨材质机械密封。
- 5、维修方便,无需拆卸管道,只要拆下泵盖螺母,取出电机及传动组件即可进行检修维护。
- 6、其独特结构,完美设计,不仅缩小泵房面积,改善了空间,而且大大节省基建投资。

Product Features

1. The pump has compact structure, small volume and beautiful appearance. Its vertical structure determines that the installation area is small.
2. It is easy to install. The inlet and outlet diameters are the same and on the same center line. There is no need to change the pipeline.
3. The pump operates stably with low noise and high concentricity of components.
4. Reliable sealing without leakage. The shaft seal is made of wear-resistant materials such as cemented carbide and silicon carbide.
5. It is convenient for maintenance. It is not necessary to disassemble the pipe. Just remove the pump cover nut and take out the motor and transmission components for maintenance.
6. Its unique structure and perfect design not only reduce the pump room area and improve the space, but also greatly save the capital construction investment.

主要用途

- 1、ISG, ISW管道泵,供输送清水物理化学性质类似于清水的其他液体之用,使用介质温度不超过80℃。适用于工业和城市给排水、高层建筑增压送水、园林喷灌、消防增压、远距离送水、采暖、浴室等冷暖水循环增压及设备配套等。
- 2、IRG, ISWR热水循环泵,适用于能源、冶金、木材加工、化工、纺织、造纸及饭店、浴室、宾馆等锅炉热水增压循环输送及城市采暖系统循环用泵,使用温度不超过120℃。
- 3、IHG, ISWH化工离心泵适用于有腐蚀介质的增压输送,使用介质温度不超过80℃。
- 4、YG, ISWY管道油泵供输送汽油、煤油、柴油等石油产品,被输送介质温度为-20℃~+120℃。

Chief Usage

1. ISG and ISW pipeline pumps are used to transport other liquids with physical and chemical properties similar to clean water, and the temperature of the medium shall not exceed 80℃. It is suitable for industrial and urban water supply and drainage, pressurization and water supply of high-rise buildings, garden sprinkler irrigation, fire pressurization, long-distance water supply, heating, bathroom and other cold and warm water circulation pressurization and equipment matching.
2. IRG, iswr hot water circulating pump is applicable to boiler hot water pressurization circulating transmission and urban heating system circulating pump in energy, metallurgy, wood processing, chemical industry, textile, papermaking, restaurants, bathrooms, hotels, etc. the operating temperature shall not exceed 120℃.
3. IHG and iswh chemical centrifugal pumps are applicable to pressurized transportation with corrosive media, and the temperature of the media shall not exceed 80℃.
4. YG and iswy pipeline oil pumps are used to transport gasoline, kerosene, diesel and other petroleum products. The temperature of the transported medium is -20℃ ~ +120℃.

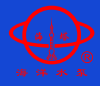

工作条件

- 1、泵系统工作压力 $\leq 16\text{MPa}$ ，即泵吸入口压力加泵扬程 $\leq 16\text{MPa}$ ，订货时请注明系统工作压力。当进口压力 $>0.4\text{MPa}$ ，或泵系统工作压力 $>16\text{MPa}$ 时，应在订货时另行提出，以便在制造时，泵的过流部分和连接部分采用相应材质满足要求。
- 2、适用介质：固体不溶物体积含量不超过单位体积的0.1%。
- 3、周围环境温度不超过 40°C ，相对湿度不超过95%。

结构说明

ISG泵结构见图。该泵由电机和泵两部分组成，泵结构包括泵体、叶轮、泵盖、机械密封等部件组成。泵为立式单级单吸离心式，进、出口设在同一水平轴线上，且口径规格相同可直接象阀门一样安装在管路的任何部位上，装卸方便，占地面积小。泵设有底座，增加泵安装的稳固性。泵体、进、出口法兰上设有取压孔，可直接将压力表装上，以保证泵长期在额定性能范围运行。

ISW结构见图。该机组由泵、电机和底座三部分组成。泵结构包括泵体、叶轮、泵盖、机械密封等零部件组成。泵为单级单吸卧式离心式，泵体和泵盖两部份是从叶轮背面处剖分的，即为后开门结构形式。大多数泵的叶轮前、后均设有密封环，并在叶轮后盖板上设有平衡孔，以平衡作用在转子上的轴向力。泵进口为轴向水平吸入，出口为垂直向上布置。泵和电机同轴，电机轴伸端采用双角接触球轴承结构可部分平衡泵的残余轴向力。泵与电机直联，安装时无需校正，具有共同底座，并用JG型隔振器进行隔振。

Working Conditions

1. The working pressure of the pump system is $\leq 16\text{MPa}$, that is, the pump suction pressure plus the pump lift is $\leq 16\text{MPa}$. Please indicate the working pressure of the system when ordering. When the inlet pressure is $>0.4\text{MPa}$, or the working pressure of the pump system is $>16\text{MPa}$, it shall be put forward separately when ordering, so that the flow passage part and connecting part of the pump can be made of corresponding materials to meet the requirements during manufacturing.
2. Applicable medium: the volume content of solid insoluble matter shall not exceed 0.1% per unit volume.
3. The ambient temperature shall not exceed 40°C , and the relative humidity shall not exceed 95%.

Structure Description

ISG structure is shown in the figure. The pump is composed of motor and pump. The pump structure consists of pump body, impeller, pump cover, mechanical seal and other components. The pump is a vertical single-stage single suction centrifugal type. The inlet and outlet are set on the same horizontal axis, and the diameter and specification are the same. It can be directly installed on any part of the pipeline like a valve. It is convenient for loading and unloading and covers a small area. The pump is equipped with a base to increase the stability of pump installation. Pressure tapping holes are set on the pump body, inlet and outlet flanges, and the pressure gauge can be directly installed to ensure that the pump operates within the rated performance range for a long time.

ISW structure is shown in the figure. The unit consists of pump, motor and base. The pump structure consists of pump body, impeller, pump cover, mechanical seal and other parts. The pump is a single-stage single suction horizontal centrifugal type. The pump body and pump cover are divided from the back of the impeller, that is, the back door structure. Most pump impellers are equipped with sealing rings at the front and rear, and balancing holes are set on the rear cover plate of the impeller to balance the axial force acting on the rotor. The pump inlet is axial horizontal suction, and the outlet is vertical upward. The pump and motor are coaxial, and the motor shaft extension end adopts a double angle contact ball bearing structure to partially balance the residual axial force of the pump. The pump and motor are directly connected without correction during installation. They have a common base and use JG vibration isolator for vibration isolation.

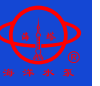

结构示意图

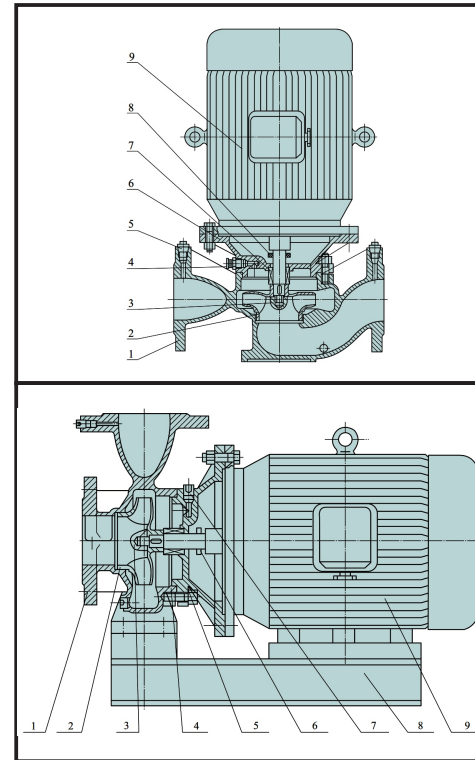

Structure diagram

序号 NO.	名称 Name	序号 NO.	名称 Name
1	泵体 Pump casing	6	泵盖 Pump cover
2	叶轮 Impeller	7	机械密封 Mechanical seal
3	叶轮螺母 Impeller nut	8	挡水圈 Water-bolching ring
4	放气阀 Air discharge valve	9	电机 Motor
5	螺塞 Plug		

序号 NO.	名称 Name	序号 NO.	名称 Name
1	泵体 Pump casing	6	挡水圈 Water-bolching ring
2	叶轮 Impeller	7	螺塞 Plug
3	叶轮螺母 Impeller nut	8	底座 Fundation
4	机械密封 Mechanical seal	9	电机 Motor
5	泵盖 Pump cover		

结构材料表

List of structural materials

材料 Material 零部件 Part	ISG	IRG	IHG	YG	ISW	ISWR	ISWH	ISWY
泵体 Pump casing	铸铁 HT200 Cast Iron HT200	铸铁 HT200 Cast Iron HT200	不锈钢304 Ss304	铸铁 HT200 Cast Iron HT200	铸铁 HT200 Cast Iron HT200	铸铁 HT200 Cast Iron HT200	不锈钢304 Ss304	铸铁 HT200 Cast Iron HT200
叶轮 Impeller	铸铁 HT200 Cast Iron HT200	铸铁 HT200 Cast Iron HT200	不锈钢304 Ss304	黄铜 Brass	铸铁 HT200 Cast Iron HT200	铸铁 HT200 Cast Iron HT200	不锈钢304 Ss304	黄铜 Brass
泵盖 Pump cover	铸铁 HT200 Cast Iron HT200	铸铁 HT200 Cast Iron HT200	不锈钢304 Ss304	铸铁 HT200 Cast Iron HT200	铸铁 HT200 Cast Iron HT200	铸铁 HT200 Cast Iron HT200	不锈钢304 Ss304	铸铁 HT200 Cast Iron HT200
挡水圈 Water-bolching ring	橡胶 Rubber	橡胶 Rubber	橡胶 Rubber	橡胶 Rubber	橡胶 Rubber	橡胶 Rubber	橡胶 Rubber	橡胶 Rubber
机械密封 Mechanical seal	碳化硅/石墨 Sic/Graphite	合金/石墨 Alloy / Graphite	合金/石墨 Alloy / Graphite	合金/石墨 Alloy / Graphite	碳化硅/石墨 Sic/Graphite	合金/石墨 Alloy / Graphite	合金/石墨 Alloy / Graphite	合金/石墨 Alloy / Graphite
螺塞 Plug	碳钢 Carbon steel	碳钢 Carbon steel	碳钢 Carbon steel	碳钢 Carbon steel	碳钢 Carbon steel	碳钢 Carbon steel	碳钢 Carbon steel	碳钢 Carbon steel
放气阀 Air discharge valve	黄铜 Brass	黄铜 Brass	黄铜 Brass	黄铜 Brass	黄铜 Brass	黄铜 Brass	黄铜 Brass	黄铜 Brass
底座 Fundation	/	/	/	/	碳钢 Carbon steel	碳钢 Carbon steel	碳钢 Carbon steel	碳钢 Carbon steel



性能参数

Table with 8 columns: 序号 NO., 型号 Type, 流量 Flow, 扬程 Head, 效率 Eff., 转速 Speed, 功率 Power, 汽蚀 NPSH. Rows 1-28.

Performance parameter

Table with 8 columns: 序号 NO., 型号 Type, 流量 Flow, 扬程 Head, 效率 Eff., 转速 Speed, 功率 Power, 汽蚀 NPSH. Rows 29-56.

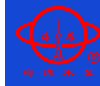

性能参数

Table with 8 columns: 序号 NO., 型号 Type, 流量 Flow, 扬程 Head, 效率 Eff., 转速 Speed, 功率 Power, 汽蚀 NPSH. Rows 57-84.

Performance parameter

Table with 8 columns: 序号 NO., 型号 Type, 流量 Flow, 扬程 Head, 效率 Eff., 转速 Speed, 功率 Power, 汽蚀 NPSH. Rows 85-112.



性能参数

Table with 8 columns: 序号 NO., 型号 Type, 流量 Flow (m³/h, L/s), 扬程 Head (m), 效率 Eff. %, 转速 Speed (r/min), 功率 Power (kW), 汽蚀 NPSH (m). Rows 113-140.

Performance parameter

Table with 8 columns: 序号 NO., 型号 Type, 流量 Flow (m³/h, L/s), 扬程 Head (m), 效率 Eff. %, 转速 Speed (r/min), 功率 Power (kW), 汽蚀 NPSH (m). Rows 141-168.



性能参数

Table with 8 columns: 序号 NO., 型号 Type, 流量 Flow (m³/h, L/s), 扬程 Head (m), 效率 Eff. %, 转速 Speed (r/min), 功率 Power (kW), 汽蚀 NPSH (m). Rows 169-196.

Performance parameter

Table with 8 columns: 序号 NO., 型号 Type, 流量 Flow (m³/h, L/s), 扬程 Head (m), 效率 Eff. %, 转速 Speed (r/min), 功率 Power (kW), 汽蚀 NPSH (m). Rows 197-224.

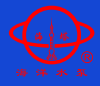

性能参数

Table with 9 columns: 序号 NO., 型号 Type, 流量 Flow, 扬程 Head, 效率 Eff., 转速 Speed, 功率 Power, 汽蚀 NPSH. Rows 225-252.

Performance parameter

Table with 9 columns: 序号 NO., 型号 Type, 流量 Flow, 扬程 Head, 效率 Eff., 转速 Speed, 功率 Power, 汽蚀 NPSH. Rows 253-280.

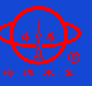

性能参数

Table with 9 columns: 序号 NO., 型号 Type, 流量 Flow, 扬程 Head, 效率 Eff., 转速 Speed, 功率 Power, 汽蚀 NPSH. Rows 281-308.

Performance parameter

Table with 9 columns: 序号 NO., 型号 Type, 流量 Flow, 扬程 Head, 效率 Eff., 转速 Speed, 功率 Power, 汽蚀 NPSH. Rows 309-336.

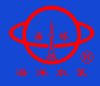

性能参数

Table with 8 columns: 序号 NO., 型号 Type, 流量 Flow, 扬程 Head, 效率 Eff., 转速 Speed, 功率 Power, 汽蚀 NPSH. Rows include models like 125-400(I)B, 125-400(I)C, 150-200, 150-200A, etc.

Performance parameter

Table with 8 columns: 序号 NO., 型号 Type, 流量 Flow, 扬程 Head, 效率 Eff., 转速 Speed, 功率 Power, 汽蚀 NPSH. Rows include models like 200-250A, 200-250B, 200-315, 200-315A, etc.



性能参数

Table with 8 columns: 序号 NO., 型号 Type, 流量 Flow, 扬程 Head, 效率 Eff., 转速 Speed, 功率 Power, 汽蚀 NPSH. Rows include models like 250-250, 250-250A, 250-315, 250-315A, etc.

Performance parameter

Table with 8 columns: 序号 NO., 型号 Type, 流量 Flow, 扬程 Head, 效率 Eff., 转速 Speed, 功率 Power, 汽蚀 NPSH. Rows include models like 300-500C, 350-250, 350-250A, 350-315, etc.



安装

- 1、安装前应仔细检查流道内有无硬质物，以免运行时损坏叶轮和泵体。
- 2、安装时管路重量不允许加在泵上，以免使泵变形，影响正常运行。
- 3、拧紧地脚螺栓，以免启动时振动对泵性能的影响。
- 4、在泵的进、出口管路上安装调节阀，在泵出口附近安装压力表，以控制泵在额定工况内运行，确保泵的正常使用寿命。
- 5、排出管路如装逆止阀应装在闸阀的外面。
- 6、泵的安方分为硬性联接和柔性联接安装。

安装方式

硬性联接

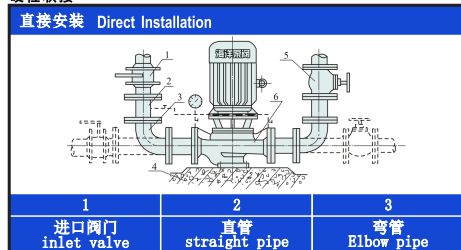

柔性联接

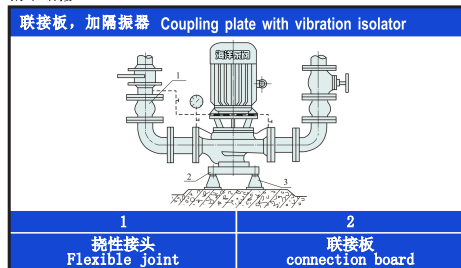

硬性联接 Rigid connection

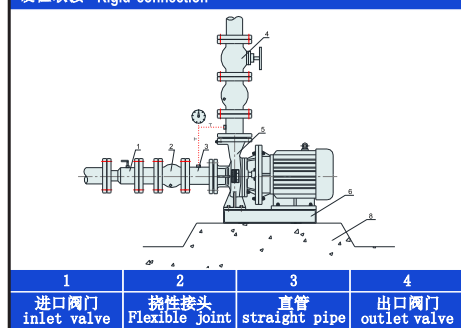

Installation

1. Before installation, carefully check whether there are hard objects in the flow passage to avoid damaging the impeller and pump body during operation.
2. During installation, the pipeline weight is not allowed to be added to the pump to avoid deformation of the pump and affecting the normal operation.
3. Tighten the foundation bolts to avoid the impact of vibration on pump performance during startup.
4. Install regulating valves on the inlet and outlet pipelines of the pump, and install pressure gauges near the pump outlet to control the operation of the pump within the rated working conditions and ensure the normal use of the pump.
5. If the discharge pipeline is equipped with a check valve, it shall be installed outside the gate valve.
6. The installation of the pump is divided into hard connection and flexible connection installation.

Installation Mode

Rigid Connection

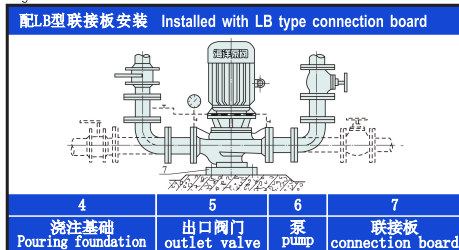

Flexible Connection

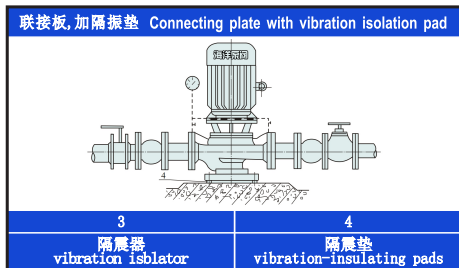

柔性联接 Flexible connection

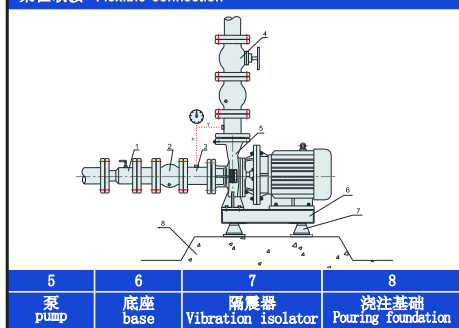

启动与停车

(一) 启动前准备

- 1、用手拨转电机风叶，叶轮应无卡磨现象，转动灵活。
- 2、打开进口阀门、打开排气阀使液体充满整个泵腔，然后关闭排气阀。
- 3、用手盘动泵以使润滑油进入机械密封端面。
- 4、点动电机，确定转向是否正确。

(二) 启动与运行

- 1、全开进口阀门，关闭吐出管路阀门。
- 2、接通电源，当泵达到正常转速后，再逐渐打开吐出管路上阀门，并调节到所需工况。
- 3、注意观察仪表读数，检查轴封泄漏情况，止吊时机械密封泄漏量<3滴/分，检查电机、轴承处温度≤70℃，如果发现异常情况，应及时处理。

(三) 停车

- 1、逐渐关闭吐出管路阀门，切断电源。
- 2、关闭进口阀门。
- 3、如环境温度低于0℃，应将泵内液体放尽，以免冻裂。
- 4、如长期停用，应将泵拆卸清洗，包装保管。

泵的维护

(一) 运行中的维护

- 1、进口管道必须充满液体，禁止泵在汽蚀状态下长期运行。
- 2、定时检查电机电流值，不得超过电机额定电流。
- 3、泵进行长期运行后，由于机械磨损，使机组噪音及振动增大时，应停车检查，必要时可更换易损件，机组大修期一般为一年。

(二) 机械密封维护

- 1、机械密封润滑应清洁无固体颗粒。
- 2、严禁机械密封在干磨情况下工作。
- 3、启动前应先盘动泵(电机)几圈，以免突然启动造成石墨环断裂损坏。
- 4、密封泄漏允差3滴/分，否则应检修。

Start and stop of the pump

(1) Preparation before starting

1. Manually pull and rotate the fan blade of the motor, and the impeller shall be free of jamming and grinding, and the rotation shall be flexible.
2. Open the inlet valve, open the exhaust valve to fill the whole pump chamber with liquid, and then close the exhaust valve.
3. Turn the pump by hand to make the lubricating fluid enter the mechanical seal face.
4. Jog the motor to determine whether the steering is correct.

(2) Start up and operation

1. Fully open the inlet valve and close the outlet pipeline valve.
2. Turn on the power supply. When the pump reaches the normal speed, gradually open the valve on the discharge pipeline and adjust it to the required working condition.
3. Pay attention to the reading of the instrument, check the leakage of the shaft seal, check that the leakage of the mechanical seal is less than 3 adjustments/min when stopping the lifting, and check that the temperature at the motor and bearing is less than or equal to 70 ℃. If any abnormality is found, it shall be handled in time.

(3) Parking

1. Gradually close the discharge pipeline valve and cut off the power supply.
2. Close the inlet valve.
3. If the ambient temperature is lower than 0 ℃, the liquid in the pump shall be drained to avoid frost cracking.
4. If the pump is out of service for a long time, it shall be disassembled, cleaned, packaged and kept.

Maintenance of pump

(1) Maintenance in operation

1. The inlet pipe must be filled with liquid, and it is forbidden to operate the pump for a long time under cavitation condition.
2. Regularly check the motor current value, which shall not exceed the motor rated current.
3. After long-term operation of the pump, if the noise and vibration of the unit increase due to mechanical wear, the pump shall be stopped for inspection, and the vulnerable parts can be replaced if necessary. The overhaul period of the unit is generally one year.

(2) Mechanical seal maintenance

1. Mechanical seal lubrication shall be clean and free of solid particles.
2. It is forbidden to work the mechanical seal under dry grinding.
3. Before starting, the pump (motor) shall be turned for several turns to prevent the graphite ring from being broken and damaged due to sudden starting.
4. The seal leakage tolerance is 3 drops / min, otherwise it shall be repaired.



故障原因和解决办法 Causes of failure and solutions

故障 fault	可能的原因 Possible causes	排除方法 Exclusion method
1、水泵不出水 1. The water pump does not discharge water	a 进出口阀门未打开, 进出管路阻塞, 叶轮流道阻塞 b 电机运行方向不对, 电机缺相转速很慢。 c 吸入管漏气。 d 泵没灌液体, 泵腔内有空气。 e 进口供水不足, 吸程过高, 底阀漏水。 f 管路阻力过大, 泵选型不当。 A the inlet and outlet valves are not opened, the inlet and outlet pipelines are blocked, and the impeller passage is blocked B the motor runs in the wrong direction, the motor is out of phase and the speed is very slow. C the suction pipe leaks. D the pump is not filled with liquid and there is air in the pump chamber. E the water supply at the inlet is insufficient, the suction lift is too high, and the bottom valve leaks. F excessive pipeline resistance and improper pump selection.	a 检查, 去除阻塞物 b 调整电机方向, 紧固电机接线。 c 拧紧各密封面, 排除空气。 d 打开泵上盖或打开排气阀, 排尽空气。 e 停机检查、调整(带吸程使用易出现此现象)。 f 减少管路弯道, 重新选泵。 A check and remove obstructions B adjust the motor direction and fasten the motor wiring. C tighten all sealing surfaces to remove air. D open the upper cover of the pump or open the exhaust valve to exhaust the air. E stop the machine for inspection and adjustment (this phenomenon is easy to occur when using with suction lift). F reduce pipeline bends and reselect pumps.
2、水泵流量不足 2. Insufficient water pump flow	a 先按1原因检查 b 管道、泵流产叶轮部分阻塞, 水垢沉积、阀门开度不足。 c 电压偏低。 d 叶轮磨损。 A check according to 1 reason first B the pipeline and impeller of the pump are partially blocked, the scale is deposited, and the valve opening is insufficient. C the voltage is low. D impeller is worn.	a 先按1排除 b 去除阻塞物, 重新调整阀门开度 c 稳压。 d 更换叶轮。 A press 1 to exclude B remove the blockage and readjust the valve opening C. voltage stabilization. D replace the impeller
3、功率过大 3. Excessive power	a 超过额定流量使用 b 吸程过高 c 泵轴承磨损 A use in excess of rated flow B suction lift too high C pump bearing is worn	a 调节流量关小出口阀门 b 降低吸程 c 更换轴承 A adjust the flow and turn down the outlet valve B lower suction lift C replace the bearing
4、噪音振动 4. Noise vibration	a 管路支撑不稳 b 液体混有气体 c 产生汽蚀 d 轴承损坏 e 电机超载发热运行 A. unstable pipeline support B liquid mixed with gas C cavitation D bearing damage E. motor overload heating operation	a 稳固管路 b 提高吸入压力排气 c 降低真空度 d 更换轴承 e 调整按5 A secure the pipeline B increase suction pressure and exhaust C reduce vacuum D replace the bearing E adjust by 5
5、电机发热 5. Motor heating	a 流量过大, 超载运行 b 碰撞 c 电机轴承损坏 d 电压不足 A. excessive flow and overload operation B collision C. motor bearing is damaged D insufficient voltage	a 关小出口阀门 b 检查排除 c 更换轴承 d 稳压 A turn down the outlet valve B check and eliminate C replace the bearing D voltage stabilization
6、水泵漏水 6. Water pump leakage	a 机械密封磨损 b 泵体有砂孔或破裂 c 密封面不平整 d 安装螺栓松懈 A mechanical seal is worn B. the pump body has sand holes or cracks C. uneven sealing surface D loose mounting bolts	a 更换 b 焊补或更换 c 修整 d 紧固 A replacement B. welding repair and replacement C finishing D ruggedness



管路损耗参考表 Pipeline friction loss table

管径 pipe diameter (mm)	流量 Flow (L/s)										
	1	2	4	6	8	10	15	20	30	40	50
25	3.27	13.0									
40	3.5	14	15								
50	0.8	3.1	13	29							
65		0.8	3.2	7.1	13	20					
75		0.4	1.6	3.3	5.9	9.6	21.6				
100			0.4	0.8	1.3	2.1	6.8	8.6	13	19.4	
125				0.23	0.4	0.63	1.3	2.7	4.1	5.9	10.7
150					0.16	0.26	0.58	1.1	1.6	2.3	4.2
175						0.11	0.27	0.5	0.74	1.05	1.9
200							0.13	0.26	0.37	0.53	0.93
250								0.07	0.12	0.18	0.30
300									0.07	0.12	0.19

阀及弯管折合直管长度(每个)

种类 Type	折合直管直径倍数 Multiple of converted straight pipe diameter	备注 remarks
全开闸阀 Fully open gate valve	12	未畅开加倍 Not open double
全开弯管 Full opening elbow	25	
截止阀 Check valve	100	
底阀 Bottom valve	100	部分堵塞加倍 Partial blockage doubling

注: 例如100mm直管, 底阀折100倍直径等于100×100=10000mm=10m直管长度, 假设流量为8L/S直管上卷, 直管损失1.3m, 则10m损失0.13m, 即一个100m底阀, 流量为8L/S时, 则损失场程0.13米。

Note: for example, for 100mm diameter pipe, 100 times the diameter of the bottom valve is equal to 100 × 100 = 10000mm = 10m diameter length, assuming that the flow is 8L/s, according to the above table, if the loss of straight pipe is 1.3m per 100m, the loss of 10m is 0.13m, that is, a 100m bottom valve. When the flow is 8L/s, the loss head is 0.13m.

一定管路直径之最大流量限制 Maximum flow limit of a certain pipeline diameter

管路直径 Pipe diameter (mm)	最大流量 Maximum flow (L/s)	最大流速 Maximum velocity (m/s)
125	30.0	2.44
150	43.0	2.45
175	60.0	2.49
200	83.3	2.69
250	133.3	2.72
300	192.0	2.71

超过此限使管路损失显著增加。
Exceeding this limit will significantly increase the pipeline loss