

▶▶▶▶ ZX系列自吸式离心泵  
Zx self-priming Centrifugal pump

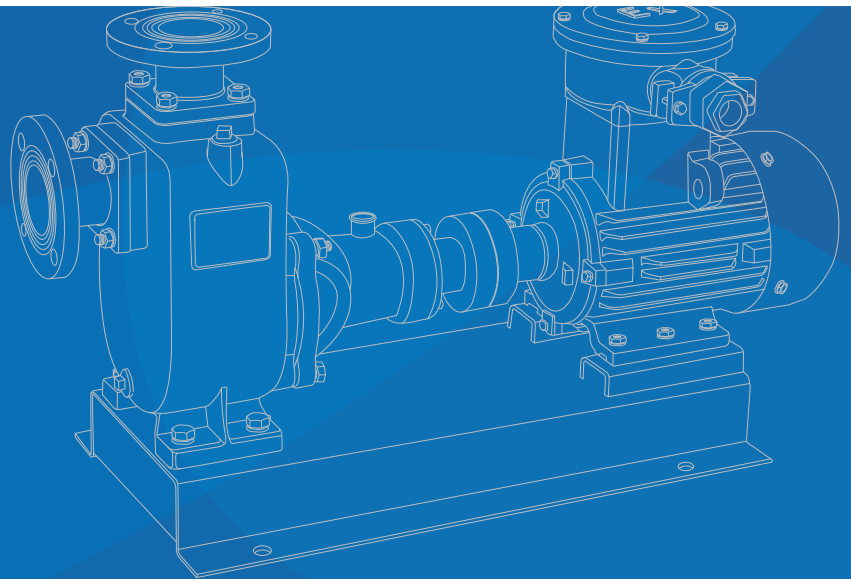

**SEAPUMP**

**上海海洋泵阀制造有限公司**  
SHANGHAI SEA PUMP & VALVE MFG CO.,LTD



## 企业简介 + AOBUTS

上海海洋泵阀制造有限公司是专业从事水泵、生活消防设备及水泵智能控制开发、生产、销售为一体的股份制企业，本公司运用先进的软件开发、设计产品保证了向顾客提供更优质的产品。

“海洋水泵，泵的海洋”，海洋产品在全国各地设有分公司以及售后服务处，产品已应用于工矿企业、城市污水处理、城市供水、石油化工、农业灌溉等行业。本厂资金雄厚，生产设备先进，检测手段完善，并拥有一批高素质的专业人才队伍，同时ISO9001:2000国际质量管理体系的良好动作，为制造出优质、可靠的产品打下坚实基础。

本公司在“以人为本，科技兴业；以诚为用，质量立业；勇于开拓，锐意进取；追求卓越，走向未来”的方针指导下，不断开拓进取创新发展，在长期的实践中形成了一套完整的质量体系，并配备了一支安装调试维护的售后服务队伍。销售网点辐射全国各大城市，产品行销全国各省、市、自治区，并出口东南亚等国。并以一流的产品、一流的服务赢得了国内外广大用户的信赖和好评。本公司以“一切为了顾客的满意”为宗旨，继往开来，与时俱进。服务于人类建设美好家园。

Shanghai HAIYANG pump & valve Co., Ltd. Is a joint-stock enterprises which specializes in the manufacture of water pumps, fire fighting equipment and pumps intelligent controlling production, sales in one. our company uses advanced software to develop and design products to ensure that customers provide better quality products.

"HAIYANG water pumps, pump of the sea", the HAIYANG products throughout the country with more than 30 branch offices as well as after-sales service, products have been used in industrial and mining enterprises, urban sewage treatment, urban water supply, petrochemicals, agriculture and irrigation sectors. Factory with a strong financial background, advanced production equipment and means of improving the detection and has a number of high-quality professional talent, while ISO9001: 2000 international quality management system of good moves, in order to create high-quality, reliable products to lay a solid foundation.

In this "people-oriented, Industrial Science and Technology; to use for Prudential, the quality of establishing themselves; to open up the courage to strive for progress; the pursuit of excellence, into the future" under the guidance of continuous innovation and development to forge ahead in long-term practice of the formation of a complete set of The quality system and is equipped with an installation of the maintenance of after-sales service team. Radiation sales outlets in major cities nationwide, product marketing provinces, municipalities and autonomous regions, and exports in countries such as South-East Asia. And first-class products, first-class service to win customers at home and abroad trust and praise. The Company take "everything for the customer satisfied" as the purpose, advance with the times, in the service of humanity home.

# 目 录

# Contents

型号意义 Type designation	01
产品概述 Product introduction	01
适用范围 Scope of application	01
主要结构件名称 The name of the primary component	01
工作原理与结构说明 How it works / Description of structure	02
性能范围图 Performance range diagram	02
性能参数 Performance parameter	03
泵的安装 Pump installation	04
泵的使用 Use of pumps	05
维护和拆装 Maintenance and disassembly	06
故障及排除方法 Faults and troubleshooting	07
管路损耗参考表 Pipeline friction loss table	08

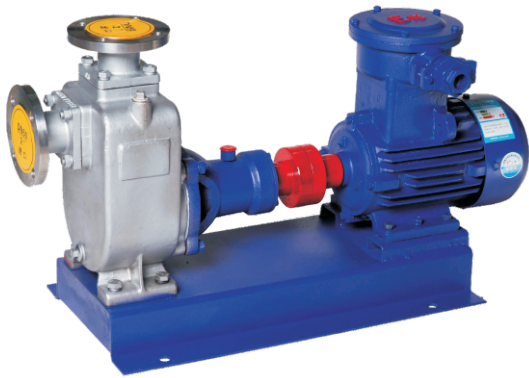

### 型号意义 Type designation

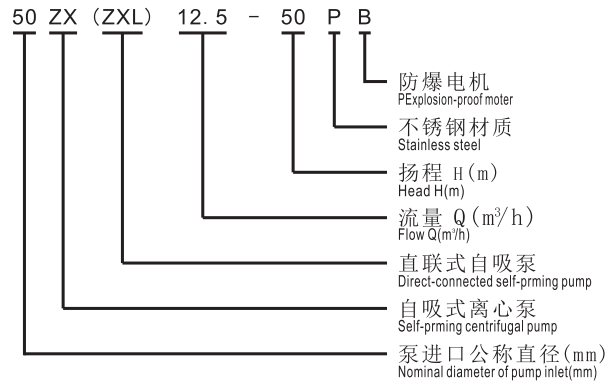

### 产品概述

本单位生产的ZX系列自吸泵是根据国内外有关技术资料经吸收、消化、改进后研制而成的节能泵类产品。该泵属自吸式离心泵，它具有结构紧凑、操作方便、运行平稳、维护容易、效率高、寿命长，并有较强的自吸能力等优点。管路中不需安装底阀，工作前只需保证泵体内储有定量引液即可。因此简化了管路系统，又改善了劳动条件。

### 适用范围

- 1、适用于城市环保、建筑、消防、化工、制药、染料、印染、酿造、电力、电镀、造纸、石油、矿山、设备冷却、油轮卸油等。
- 2、适用于清水、海水及带有酸、碱度的化工介质液体和带有一般糊状的浆料（介质粘度≤100厘珀、含固量可达30%以下）。
- 3、装上摇臂式喷头，又可将水冲到空中后，散成细小雨滴进行喷雾，是农场、苗圃、果园、茶园的良好机具。
- 4、可和任何型号、规格的压滤机配套使用，将浆料送带滤机进行压滤的配套泵种。

### 主要结构件名称

### Product introduction

The ZX series self-priming pump produced by our company is a kind of energy-saving pump developed by absorbing, digesting and improving relevant technical data at home and abroad. The pump is a self-priming Centrifugal pump, which has the advantages of compact structure, convenient operation, stable operation, easy maintenance, high efficiency, long life, and strong self-priming capacity. In the pipeline does not need to install the bottom valve, before the work only needs to ensure that the pump body has the quantitative fluid to be able to store. Therefore, the pipeline system is simplified and the working conditions are improved.

### SCOPE of application

1. Suitable for city environment protection, construction, fire fighting, chemical industry, pharmacy, dyestuff, printing and dyeing, brewing, electric power, electroplating, paper making, petroleum, mine, equipment cooling, oil tanker unloading, etc. .
2. It is suitable for clear water, sea water, chemical medium liquid with acidity and alkalinity and general paste size (medium viscosity ≤100 cm per unit area, solid content up to 30%).
- 3, equipped with a rocker-type nozzle, but also the water into the air, scattered into small raindrops for spray, is a farm, nursery, orchard, tea garden good machinery.
- 4, can and any model, specifications of the filter press supporting the use of slurry belt filter press for filtering the matching pump.

### The name of the primary component

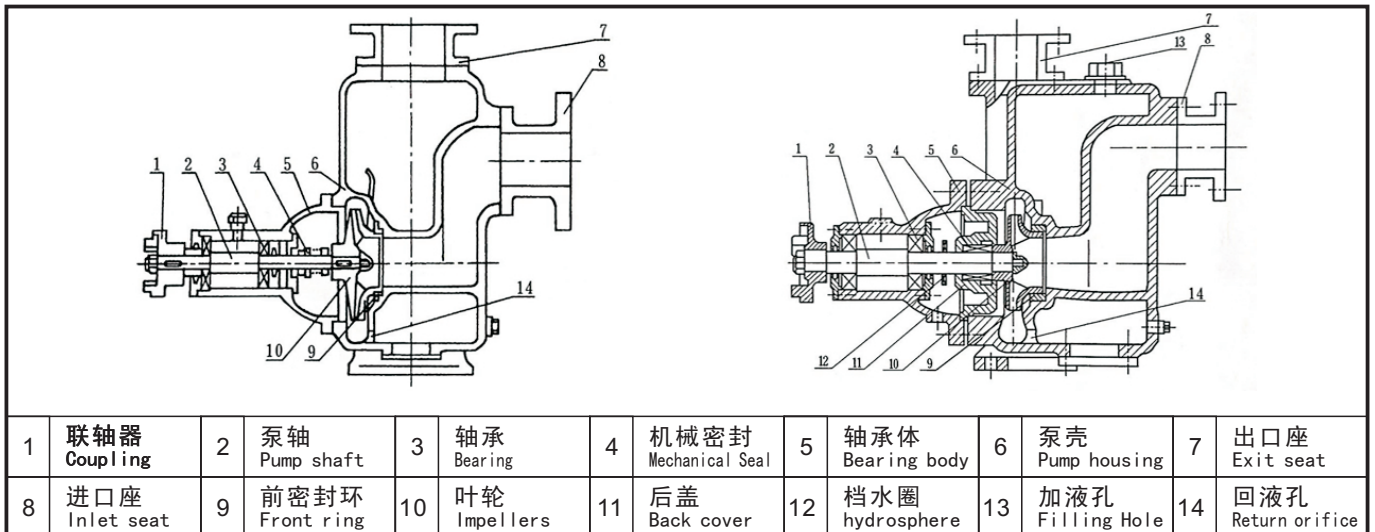



### 工作原理与结构说明

该泵均采用轴向回液的泵体结构。泵体由吸入室、储液室、涡卷室、回液孔、气液分离室等组成。泵正常启动后，叶轮将吸入室所存的液体及吸入管路中的空气一起吸入，并在叶轮内得以完全混合，在离心力的作用下，液体夹带着气体向涡卷室外缘流动，在叶轮的外缘上形成有一定厚度的白色泡沫带及高速旋转液环。气液混合物通过扩散管进入气液分离室。此时，由于流速突然降低，较轻的气体从混合气液中被分离出来，气体通过泵体吐出口继续上升排出。脱气后的液体回到储液室，并由回液孔再次进入叶轮，与叶轮内部从吸入管路中吸入的气体再次混合，在高速旋转的叶轮作用下，又流向叶轮外缘……。随着这个过程周而复始地进行下去，吸入管路中的空气不断减少，直到吸尽气体，完成自吸过程，泵便投入正常作业。

在一些泵的轴承体底部还没有冷却室。当轴承发热引起轴承体温升超过70℃时，可在冷却室处通过任意一只冷却液管接头，注入冷却液循环冷却。泵内部防止液体由高压区向低压区泄漏的密封机构是前后密封环，前密封环装在泵体上，后密封环装在轴承体上，当泵经长期运转密封环磨损到一定程度，并影响到泵的效率 and 自吸性能时，应给予更换。

### How it works / Description of structure

The pump body structure of axial return liquid is adopted. The pump body consists of suction chamber, Liquid Storage Chamber, Scroll Chamber, Return Liquid Hole, gas-liquid Separation Chamber and so on. After the pump starts normally, The impeller inhales the liquid stored in the suction chamber together with the air in the suction pipe. Liquid entrained gas flow to the outer edge of the Scroll Chamber, forming a certain thickness of white foam on the outer edge of the impeller and high-speed rotating liquid ring. The gas-liquid mixture enters the gas-liquid separation chamber through a diffusion tube. At this point, the lighter gas is separated from the mixture due to a sudden drop in velocity. The gas continues to rise and exit through the pump body. The degassed liquid returns to the reservoir and reenters the impeller through the reflow hole, mixing again with the gas sucked in from the suction pipe inside the impeller and flowing to the outer edge of the impeller under the action of the high-speed rotating impeller... As the process continues, the amount of air sucked into the tube decreases. Until the exhaust gas, the completion of the self-priming process, the pump will be put into normal operation.

In some pumps there is no cooling chamber at the bottom of the bearing body. When the bearing heat causes the bearing body temperature to rise more than 70 °C, the cooling fluid can be injected into the cooling chamber through any one of the cooling fluid pipe joints for circulating cooling. The sealing mechanism to prevent the leakage of liquid from high pressure area to low pressure area inside the pump is the front and back sealing rings, the Front Sealing Rings are installed on the pump body, and the back sealing rings are installed on the bearing body. And affect the efficiency of the pump and self-priming performance. Replacement shall be given.

### 性能范围图

### Performance range diagram

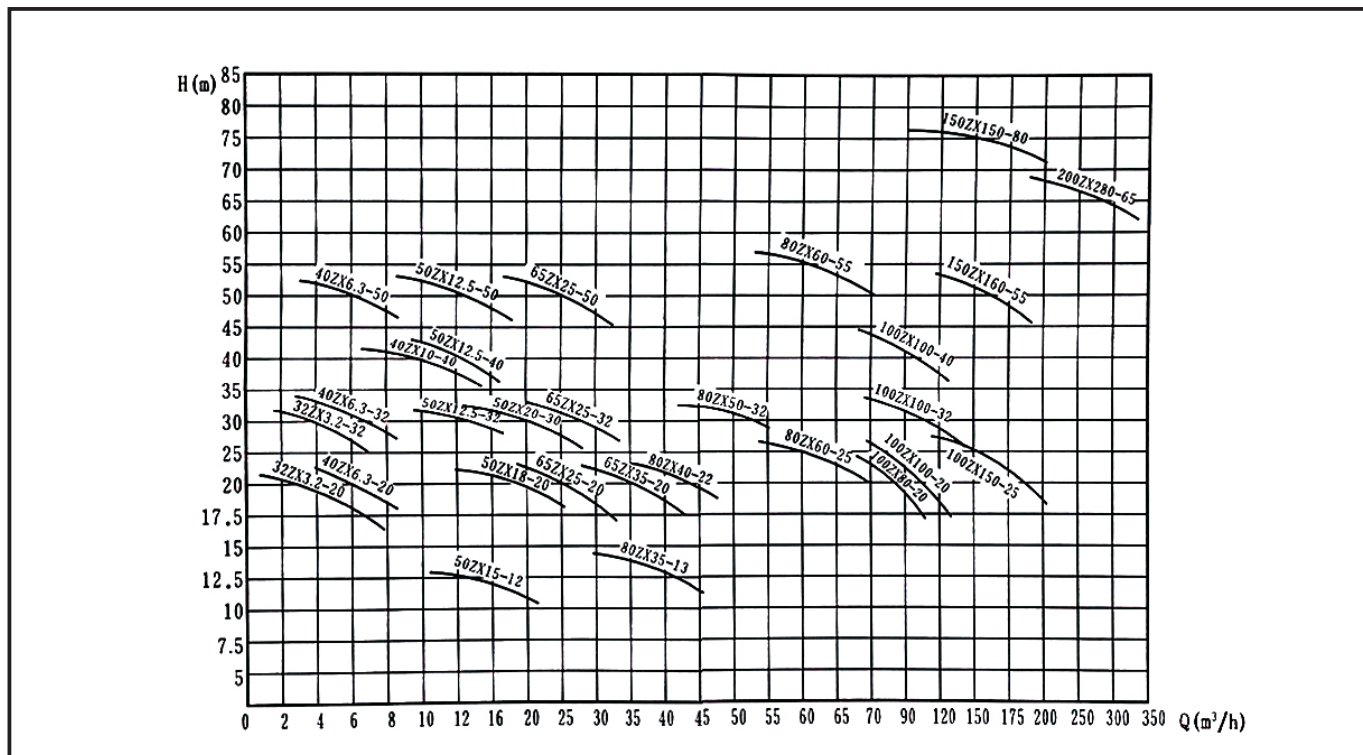



## 性能参数 Performance parameter

序号 Number	型号 Model number	流量Flow m³/h	扬程Head m	功率Power kW	转速Speed r/min	电压Voltage V	自吸时间 Self Priming time S
1	25ZX(ZXL)3.2-20	3.2	20	0.75	2900	380	120
2	25ZX(ZXL)3.2-32	3.2	32	1.5	2900	380	100
3	32ZX(ZXL)3.2-20	3.2	20	1.5	2900	380	120
4	32ZX(ZXL)3.2-32	3.2	32	1.5	2900	380	100
5	40ZX(ZXL)6.3-20	6.3	20	1.5	2900	380	120
6	40ZX(ZXL)6.3-32	6.3	32	2.2	2900	380	100
7	40ZX(ZXL)10-40	10	20	4	2900	380	100
8	40ZX(ZXL)6.3-50	12.5	50	4	2900	380	80
9	50ZX(ZXL)15-12	15	12	1.5	2900	380	120
10	50ZX(ZXL)18-20	18	20	2.2	2900	380	120
11	50ZX(ZXL)12.5-32	12.5	32	3	2900	380	100
12	50ZX(ZXL)20-30	20	30	4	2900	380	100
13	50ZX(ZXL)14-35	14	35	4	2900	380	100
14	50ZX(ZXL)10-40	15	40	4	2900	380	100
15	50ZX(ZXL)12.5-50	12.5	50	5.5	2900	380	100
16	50ZX(ZXL)15-60	16	60	7.5	2900	380	80
17	50ZX(ZXL)15-70	15	70	11	2900	380	80
18	50ZX(ZXL)20-75	20	75	11	2900	380	80
19	65ZX(ZXL)30-15	30	15	3	2900	380	120
20	65ZX(ZXL)25-17	25	17	3	2900	380	120
21	65ZX(ZXL)25-32	25	32	5.5	2900	380	120
22	65ZX(ZXL)25-50	25	50	7.5	2900	380	100
23	65ZX(ZXL)25-75	25	70	15	2900	380	80
24	80ZX(ZXL)35-13	35	13	3	2900	380	120
25	80ZX(ZXL)35-17	35	17	4	2900	380	120
26	80ZX(ZXL)43-17	43	17	4	2900	380	120
27	80ZX(ZXL)40-22	40	22	5.5	2900	380	120
28	80ZX(ZXL)50-20	50	20	5.5	2900	380	120
29	80ZX(ZXL)50-25	50	25	7.5	2900	380	120
30	80ZX(ZXL)50-32	50	32	7.5	2900	380	120
31	80ZX(ZXL)60-40	60	40	11	2900	380	100
32	80ZX(ZXL)50-50	50	50	15	2900	380	100
33	80ZX(ZXL)60-55	60	55	18.5	2900	380	100
34	80ZX(ZXL)60-70	60	70	22	2900	380	80
35	100ZX(ZXL)100-20	100	20	11	2900	380	120
36	100ZX(ZXL)100-32	100	32	15	2900	380	120
37	100ZX(ZXL)100-40	100	40	18.5	2900	380	120
38	100ZX(ZXL)100-50	100	50	22	2900	380	100
39	100ZX(ZXL)100-65	100	65	30	2900	380	100
40	100ZX(ZXL)70-80	70	80	30	2900	380	80
41	150ZX(ZXL)150-20	150	20	18.5	2900	380	120
42	150ZX(ZXL)150-32	150	32	22	2900	380	120
43	150ZX(ZXL)200-26	200	26	30	2900	380	120
44	150ZX(ZXL)160-55	160	55	45	2900	380	100
45	150ZX(ZXL)170-65	170	65	55	2900	380	80
46	150ZX(ZXL)160-80	160	80	55	2900	380	80
47	200ZX(ZXL)400-32	400	32	55	1450	380	120
48	200ZX(ZXL)280-63	280	63	90	1450	380	80
49	250ZX(ZXL)500-30	500	30	75	1450	380	120
50	250ZX(ZXL)400-50	400	50	90	1450	380	100



## 泵的安装

1、在泵与电动机直联传动时，应注意泵轴与电动机输出的同轴度；泵安装的准确与否对泵的运行平稳性和使用寿命有较大的影响，因此必须仔细认真地安装和校正。

2、泵联轴器必须用螺母紧固好，并锁紧螺母，谨防螺母松动，否则易引起叶轮窜动，造成机械故障。

3、为使泵体内能够保持一定的储存液，以达到较好的自吸能力和防止机械密封的干摩擦，必须使泵的进口高于泵轴中心线。

4、吸入管路的安装应注：

a. 吸入口的安装高度不能超过5米，在条件许可时，吸入口的安装高度应尽可能地低于水池最低的储水平面，并尽量缩短吸入管的长度，少装弯头，这样有利于缩短自吸时间，提高自吸功能。

b. 吸入管路中的阀门、法兰等应严防漏气或渗漏液体，即吸入管路不允许有漏气现象存在。

c. 应防止泵体内吸入固体等杂物，为此吸入管路上应设置过滤器。过滤器的有效过流面积应为吸入管截面的2-3倍，过滤器应定期检查。

d. 吸入管路和吐出管路应有自己的支架，泵体本身不允许承受管路的负荷。

5、泵在安装时，应使泵及管路的静电接地电阻达到其规定要求。

6、安装时应严格检查泵壳及管路中有无石块，铁砂等杂物。

7、校正泵联轴器及电机动联轴器的安装间隙及同轴度，其不同轴度允许偏差为0.1毫米。泵轴和电动机轴的高度差可在底脚上垫铜皮或铁皮调整。

8、在机组实际运转3-4小时后，作最后检查，如无不良现象，则认为安装已妥，在试运转中应检查轴承的温度，轴承体的温度不宜超过70℃。

9、该泵轴承体凡设有冷却室装置的冷却水接头供配内孔为 $\Phi 12$ 的胶管或塑料管之用，其螺纹尺寸为M12×1.75。

10、在泵的出口管路上如装有单向阀而在自吸过程中不能使泵顺利地排出气体时，应在泵的出口处加接排气小管及阀。

## Pump installation

1. When the pump is directly connected with the motor, attention should be paid to the coaxiality of the pump shaft and the motor output. The accuracy of the pump installation has a great influence on the running stability and service life of the pump, so it must be carefully installed and corrected.

2. pump coupling must be fixed with a nut, and lock nuts, guard against loose nuts, otherwise easy to cause impeller movement, causing mechanical failure.

3. in order to make the pump body can maintain a certain amount of liquid storage, in order to achieve a better self-priming capacity and prevent dry friction of mechanical seals, the pump must be imported higher than the pump shaft centerline.

4. suction line installation should be noted:

A. The installation height of the suction inlet should not exceed 5 meters. When conditions permit, the installation height of the suction inlet should be as low as possible below the lowest water level of the tank, and the length of the suction pipe should be shortened as far as possible, with fewer elbows installed, which is beneficial to shortening the self-suction time, improve self-priming.

B. Suction pipeline valves, flanges should be strict leakage or leakage of liquid, that is, there is no leakage of gas inhalation pipeline.

C. The pump body should be prevented from inhaling solids and other sundries. Filters should be installed on the suction pipe for this purpose. Filter effective flow area should be inhalation Tube cross-section of 2-3 times, filter should be checked regularly.

D. The suction line and the discharge line shall have their own support, and the pump body itself shall not bear the load of the line.

5. When the pump is installed, the static grounding resistance of the pump and the pipeline should meet the requirements.

6. the installation should be strictly check the pump Shell and pipeline there is no stone, iron sand and other sundry.

7. Adjust the installation clearance and coaxiality of pump coupling and motor coupling, the tolerance of different coaxiality is 0.1 mm. Pump shaft and motor shaft height difference can be in the foot pad copper or iron skin adjustment.

8. in the actual operation of the Unit 3-4 hours after the final inspection, if there is no bad phenomenon, the installation is considered appropriate, in the trial operation should check the temperature of the bearing, bearing body temperature should not exceed 70℃.

9. Where the bearing body of the pump is provided with a cooling water joint of a cooling chamber device for the use of rubber or plastic pipes with inner holes of  $\Phi 12$ , the thread size is M12 × 1.75.

10. in the pump outlet pipeline such as a one-way valve installed in the self-priming process can not make the pump smoothly exhaust gas, the pump should be added at the outlet of the exhaust pipe and valve.



### 泵的使用

#### (一)、启动前的准备及检查工作:

1. 本系列自吸泵, 根据泵的工作运转状况, 分别采用优质钙基黄油和10号机油进行润滑, 如果采用黄油润滑的泵应定期向轴承箱内加注黄油, 采用机油润滑的泵, 如果油位不足, 则加足之。

2. 检查泵壳内的储液是否高于叶轮的上边缘, 如果不足, 可以从泵壳上的加液口处直接向泵体内注入储液, 不应在储液不足的情况下启动运转, 否则泵不能正常工作, 且易损坏机械密封。

3. 检查泵的转动部件是否有卡住磕碰现象。

4. 检查泵体底脚及各联结处螺母有无松动现象。

5. 检查泵轴与电动机主轴的同轴度和平行度。

6. 检查进口管路是否漏气, 如有漏气, 必须设法排除。

7. 打开吸入管路的阀门, 稍开(不要全开)出口控制阀。

#### (二)、启动及操作:

1. 点动自吸泵, 注意泵轴的转向是否正确。

2. 注意转动时有无不正常的声响和震动。

3. 致意压力表和真空表读数, 启动后当压力表及真空表的读数经过一段时间后的波动而指示稳定, 说明泵内已经上液, 进入正常输液过程。

4. 在泵进入正常输液作业前即自吸过程中, 应特别注意泵内水温上升情况. 如果这个过程过长, 自吸泵内水温过高, 即停泵检查原因。

5. 如果泵内液体温度过高而引起自吸困难, 那么可以暂时停机, 利用吐出管路中的液体倒流回泵内或向泵体上的加储液口处直接向泵内补充液体, 使泵内液体降温, 然后启动即可。

6. 泵在工作过程中如发生强烈振动和噪声, 有可能是泵发生气蚀所致, 气蚀产生的原因有两种: 一是进口管流速过大, 二是吸程过高. 流速过大时可调节出口控制阀, 升高压力表读数, 在进口管路有堵塞时则应及时排除; 吸程太高时可适当降低泵的安装高度。

7. 泵在工作过程中因故停泵, 需再启动时, 出口控制阀应稍开(不要全闭), 这样既有利于自吸过程中气体从吐出口排出, 又能保证泵在较轻的负荷下启动。

8. 注意检查管路系统有无渗漏现象。

#### (三)、停泵:

1. 首先必须关闭吐出管路上的闸阀。

2. 使泵停止转动。

3. 在寒冷季节, 应将泵体内的储液和轴承体冷却室内的水放空, 以防冻裂机件。

### Use of pumps

#### (1) Preparation and inspection before startup:

1. This series of self-priming pumps are lubricated with high-quality calcium base grease and No. 10 engine oil according to the working conditions of the pump. If the pump lubricated with grease should be regularly filled with grease in the bearing box and lubricated with machine oil if the oil level of the sliding pump is insufficient, add enough.

2. Check whether the liquid storage in the pump casing is higher than the upper edge of the impeller. If it is insufficient, the liquid storage can be directly injected into the pump from the liquid filling port on the pump casing. Do not start the operation when the liquid storage is insufficient, otherwise the pump cannot work normally and the mechanical seal is easy to be damaged

3. Check whether the rotating parts of the pump are stuck and bumped

4. Check whether the pump foot and nuts at each connection are loose

5. Check the coaxiality and parallelism of pump shaft and motor spindle

6. Check whether there is air leakage in the inlet pipeline. If there is air leakage, try to eliminate it

7. Open the valve of the suction pipeline and slightly open (do not fully open) the outlet control valve

#### (2) , startup and operation:

1 jog the self-priming pump and pay attention to whether the rotation direction of the pump shaft is correct

2. Pay attention to whether there is abnormal sound and vibration during rotation

3. Pay attention to the readings of pressure gauge and vacuum gauge. After startup, when the readings of pressure gauge and vacuum gauge fluctuate after a period of time, the indication is stable, indicating that the pump has been filled with liquid and enters the normal infusion process

4. Pay special attention to the rise of water temperature in the pump before the pump enters the normal infusion operation, that is, during the self-priming process. If this process is too long and the water temperature in the self-priming pump is too high, stop the pump to check the cause

5. If the temperature of the liquid in the pump is too high and it is difficult to self-priming, it can be stopped temporarily, and the liquid in the discharge pipeline can be used to flow back into the pump or directly supplement the liquid to the pump at the liquid filling and storage port on the pump body to cool the liquid in the pump, and then start it

6. In case of strong vibration and noise during the operation of the pump, it may be caused by cavitation. There are two reasons for cavitation: one is that the flow rate of the inlet pipe is too high, and the other is that the suction lift is too high. When the flow rate is too high, the outlet control valve can be adjusted to increase the reading of the pressure gauge. If the inlet pipeline is blocked, it should be eliminated in time; When the suction lift is too high, the installation height of the pump can be appropriately reduced

7. When the pump stops for some reason during operation and needs to be restarted, the outlet control valve shall be slightly opened (not fully closed), which is not only conducive to the discharge of gas from the outlet during self-priming, but also ensure that the pump can be started under light load

8. Check the pipeline system for leakage

#### (3) . pump shutdown:

1. First, the gate valve on the discharge pipeline must be closed

2. Stop the pump

3. In the cold season, the liquid storage in the pump body and the water in the cooling chamber of the bearing body shall be vented to prevent cracking



## 维护和拆装

该泵的特点是结构简单可靠，经久耐用。在泵正常情况下，一般不需要经常拆开保养。当发现故障后随时给予排除既可。

### 1、维护该泵时应注意几个主要部位：

A、滚动轴承：当长期运行后，轴承磨损到一定程度时，须进行更换。

B、前密封环、后密封环：当密封环磨损到一定程度时，须进行更换。

C、机械密封：机械密封在不漏液的情况下，一般不应拆开检查。若轴承体下端泄漏口处产生严重泄漏时，则应对机械密封进行拆检。装拆机械密封时，必须轻取轻放，注意配合面的清洁，保护好静环和动环的镜面，严禁敲击碰撞。因机械密封而产生泄漏的原因主要是摩擦副镜面拉毛所致。其修复办法：可对摩擦副端面进行研磨使恢复镜面。机械密封产品泄漏的另一原因是O形圈安装不当、或者变开老化所致。此时则需更换O形圈进行重新装配。

### 2、泵拆装顺序：

A、拆下电动机或脱出联轴器。

B、拆出轴承体总成，检查叶轮和前口环的径向间隙，检查叶轮螺母有无松动。

C、拆下叶轮螺母，拉出叶轮，检查叶轮和后密封环的径向间隙。

D、松开机械密封的紧定螺钉，拉出机械密封的动环部分，检查动、静环端面的贴合情况，检查O形密封圈密封情况。

E、旋出联轴器的紧定螺钉，拉出联轴器。

F、拆下轴承端盖，拆出泵轴和轴承。

G、安装时以相反顺序进行装配即可。

## Maintenance and disassembly

The pump is characterized by simple and reliable structure and durability. Under normal conditions, the pump generally does not need to be disassembled and maintained frequently. When a fault is found, it can be eliminated at any time.

### 1. When maintaining the pump, pay attention to several main parts:

A. Rolling bearing: when the bearing is worn to a certain extent after long-term operation, it must be replaced.

B. Front seal ring and rear seal ring: when the seal ring is worn to a certain extent, it must be replaced.

C. Mechanical seal: under the condition of no liquid leakage, the mechanical seal shall not be disassembled for inspection. In case of serious leakage at the leakage port at the lower end of the bearing body, the mechanical seal shall be disassembled and inspected. When assembling and disassembling the mechanical seal, it must be handled with care, pay attention to the cleanness of the mating surface, protect the mirror surface of the static ring and the moving ring, and it is strictly prohibited to knock and collide. The leakage caused by the mechanical seal is mainly caused by the galling of the mirror surface of the friction pair. The repair method: grind the end face of the friction pair to restore the mirror. Another reason for the leakage of mechanical seal products is the improper installation of O-ring or the aging of opening. At this time, replace the O-ring for reassembly.

### 2. Disassembly sequence of pump:

A. Remove the motor or the coupling.

B. Remove the bearing body assembly, check the radial clearance between the impeller and the front ring, and check whether the impeller nut is loose.

C. Remove the impeller nut, pull out the impeller, and check the radial clearance between the impeller and the rear sealing ring.

D. Loosen the set screw of the mechanical seal, pull out the moving ring part of the mechanical seal, check the fit of the end faces of the moving and stationary rings, and check the sealing of the O-ring seal.

E. Unscrew the set screw of the coupling and pull out the coupling.

F. Remove the bearing end cap and remove the pump shaft and bearing.

G. Assemble in reverse order during installation.



## 故障及排除方法

## Faults and troubleshooting

故障 fault	产生原因 Cause	排除方法 Exclusion method
水泵不出水 The water pump does not discharge water	1. 泵壳内未加储液或储液不足 1. There is no or insufficient liquid storage in the pump casing 2. 吸入管路漏气 2. Air leakage of suction pipeline 3. 转速太低 3. The speed is too low 4. 吸程太高或吸入管路过长 4. The suction lift is too high or the inlet pipeline is too long 5. 机械密封泄漏量过大 5. Excessive leakage of mechanical seal 6. 吸入管路气体不能从出口排出 6. The gas in the suction pipeline cannot be discharged from the outlet	1. 加足储液 1. Add enough liquid storage 2. 检查并排除漏气现象 2. Check and eliminate air leakage 3. 调整转速 3. Adjust the speed 4. 降低吸程或缩短吸入管路 4. Reduce the suction lift or shorten the suction pipeline 5. 修复或更换 5. Repair or replace 6. 使之排出 6. Drain it
杂音和振动较大 High noise and vibration	1. 底脚不稳 1. Unstable footing 2. 泵轴弯曲 2. The pump shaft is bent 3. 汽蚀现象 3. Cavitation 4. 轴承磨损严重 4. The bearing is seriously worn 5. 进口管路内有杂物 5. There are sundries in the inlet pipeline 6. 泵与电动机两者主轴不同心 6. The main shafts of pump and motor are not concentric	1. 加固 1. Reinforcement 2. 更换或校正 2. Replace or correct 3. 调整工况 3. Adjust working conditions 4. 更换 4. Replace 5. 清除杂物 5. Remove sundries 6. 调整同轴度 6. Adjust the coaxiality
出水量不足 Insufficient water output	1. 叶轮流道与吸入管被堵塞 1. Impeller flow passage and suction pipe are blocked 2. 叶轮或叶轮密封磨损严重 2. The impeller or impeller seal is seriously worn 3. 功率不足或转速太低 3. Insufficient power or low speed	1. 排除堵塞物 1. Remove the blockage 2. 更换口环 2. Replace the mouth ring 3. 加足功率、调至额定转速 3. Increase the power and adjust it to the rated speed
轴功率消耗过大 Excessive shaft power consumption	1. 流量过大 1. Excessive flow 2. 转速太高 2. The speed is too high 3. 泵轴弯曲或叶轮卡碰 3. The pump shaft is bent or the impeller is stuck 4. 泵内流道堵塞或被卡住 4. The flow passage in the pump is blocked or stuck	1. 升高出口压力 1. Increase the outlet pressure 2. 适当降低 2. Appropriate reduction 3. 更换或校正 3. Replace or correct 4. 排除堵塞特 4. Remove blockage



### 管路损耗参考表 Pipeline friction loss table

管径 pipe diameter (mm)	流量 Flow (L/s)																						
	1	2	4	6	8	10	15	20	25	30													
25	3.27	13.0																					
40	3.5	14	15																				
50	0.8	3.1	13	29																			
65		0.8	3.2	7.1	13	20																	
75		0.4	1.6	3.3	5.9	9.6	21.6																
100			0.4	0.8	1.3	2.1	6.8	8.6	13	19.4													
125				0.23	0.4	0.63	1.3	2.7	4.1	5.9	10.7												
150					0.16	0.26	0.58	1.1	1.6	2.3	4.2	6.4	9.4										
175						0.11	0.27	0.5	0.74	1.05	1.9	2.9	4.3	5.8	7.7	9.6							
200							0.13	0.26	0.37	0.53	0.93	1.5	2.1	2.9	3.7	4.7	6.1	7.2	8.5	140	160		
250								0.07	0.12	0.18	0.30	0.48	0.68	0.93	1.2	1.5	1.9	2.3	2.8	3.3	3.7	4.9	5.2
300									0.07	0.12	0.19	0.27	0.37	0.49	0.6	0.76	0.9	1.1	1.3	1.5	2.0	2.4	3.0

直管摩擦损失简表(供估计用)  
管100m直管损失米数以新铸铁管为标准, 旧管加倍

Brief table of friction loss of straight pipe (for estimation)  
The loss meter of 100m straight pipe is the standard of new cast iron pipe, and the loss meter of old pipe is doubled

### 阀及弯管折合直管长度(每个)

Length of straight pipe converted from valve and elbow (each)

种类 type	折合直管直径倍数 Multiple of converted straight pipe diameter	备注 remarks
全开闸阀 Fully open gate valve	12	未畅开加倍 Not open double
全开弯管 Full opening elbow	25	
逆止阀 Check valve	100	
底阀 Bottom valve	100	部分堵塞加倍 Partial blockage doubling

注: 例如100mm直径管, 底阀折100倍直径等于100×100=10000mm=10m直径长度, 假定流量为8L/S, 流量每100m损失1.3m, 则10m损失0.13m, 即一个100m底阀, 流量为8L/S时, 则损失扬程0.13米。

Note: for example, for 100mm diameter pipe, 100 times the diameter of the bottom valve is equal to 100 × 100 = 10000mm = 10m diameter length, assuming that the flow is 8L/s. according to the above table, if the loss of straight pipe is 1.3m per 100m, the loss of 10m is 0.13m, that is, a 100m bottom valve. When the flow is 8L/s, the loss head is 0.13m.

### 一定管路直径之最大流量限制

Maximum flow limit of a certain pipeline diameter

管路直径 Pipe diameter (mm)	最大流量 Maximum flow (L/s)	最大流速 Maximum velocity (m/s)
25	1	2.04
38	2.5	1.69
50	4.17	2.12
65	6.67	2.01
75	10.0	2.26
100	18.4	2.33

管路直径 Pipe diameter (mm)	最大流量 Maximum flow (L/s)	最大流速 Maximum velocity (m/s)
125	30.0	2.44
150	43.0	2.45
175	60.0	2.49
200	83.3	2.69
250	133.3	2.72
300	192.0	2.71

超过此限使管路损失显著增加。  
Exceeding this limit will significantly increase the pipeline loss

由于我们在不断努力改进产品，我们保留样本数据更改的权利，敬主谅解。

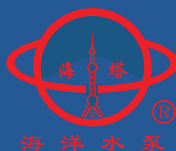

Shanghai Sea  
Pump & Valve Mtg Co.,ltd

**上海海洋泵阀制造有限公司**

地址：上海市金山区山阳镇山富东路365号  
电话：(0086)-021-63546554 63803848  
传真：(0086)-021-33550508  
网址：[www.sea-pump.com](http://www.sea-pump.com)  
邮箱：[seapump@foxmail.com](mailto:seapump@foxmail.com)